

HDG ENGINEERED PRODUCTS

Beam to Post Bracket Assembly



*Featuring:
The H5-GBL3
Bracket*

209 Tidwell Drive Alpharetta, Georgia 30004 Office 770-777-7007 ~ ext. 234 E-mail: info@hdgep.com
USPTO No. 10,024,046: Bracket Bracing System - Copyright © 2018 HDG, Inc. All Rights Reserved - Terms of Use Listed @ www.hdgep.com - 1

Beam to Post Bracket Assembly

General Construction Notes

**** Read Guide Completely Before Installation ****

- **Check for Additional Requirements**
 - **Per Deck Design Professional AND local code authority**
- **Water Intrusion**
 - ****INSTALLER IS RESPONSIBLE FOR PREVENTING WATER INTRUSION****
 - *Verify all bolts and caulks are tightened*
- **Fasteners:**
 - **Installed ONLY in provided and specified holes**
 - **Are to meet or exceed local code requirements.**
 - **Recommended: HDG ASTM 123 Hot Dipped Galvanized or Stainless Steel**

**Instructions are not intended to replace deck construction plans.
Shown for product illustration purposes only.**

 HDG
EXCELLENCE IN PRODUCTS

Notch the one end of each deck post to accommodate the beam used.

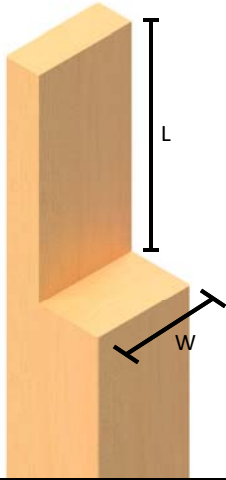

In this case, we are using a 3 1/2" x 12" LVL or PSL beam, so the notch is 11.25" long (L) and 3" deep (W).

3

 HDG
EXCELLENCE IN PRODUCTS

Set the beam across the posts as shown.

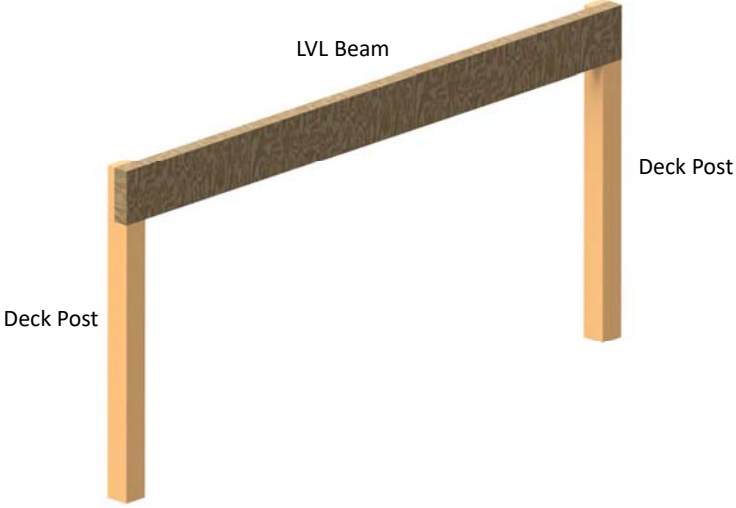

Fasten overlapped boards temporarily to hold them in place.

4

Place the H5-GBL3 bracket flush against post, insuring the bracket is flush along the bottom of the beam. 

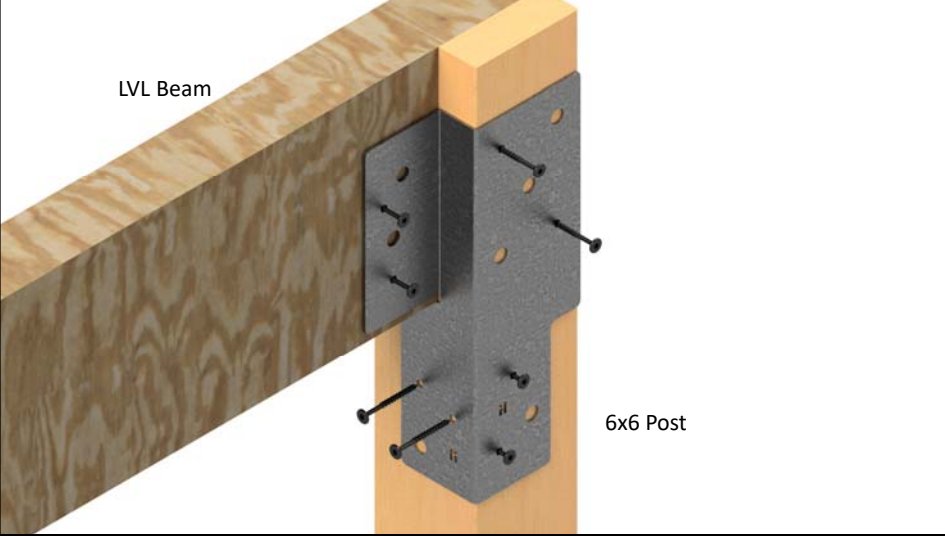

LVL Beam

6x6 Post

(Optional: can use screws or nails to temporarily hold in place.)

5

Drill, using each bolt hole in bracket as guides, through all lumber with a minimum 1/2" hole for 1/2" bolts or 5/8" hole for 5/8" bolt. 

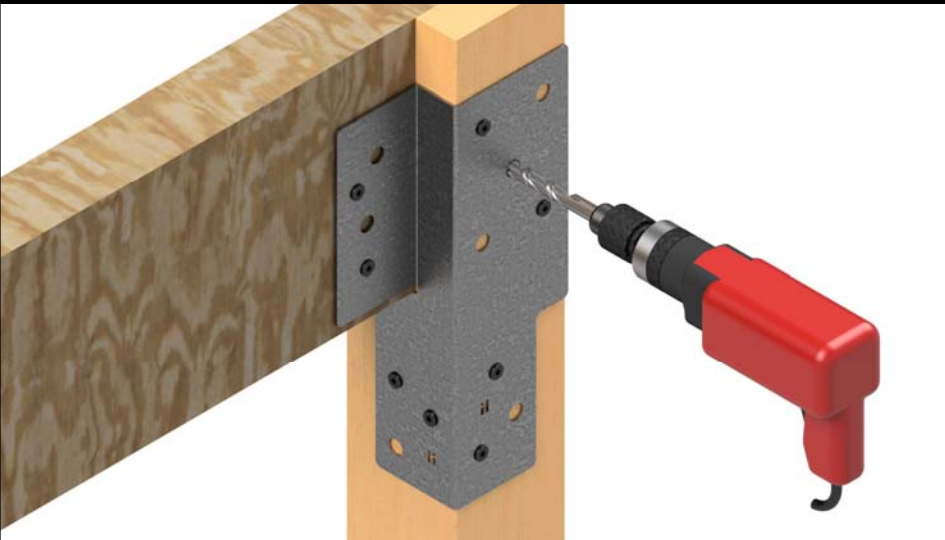

6

Pushing bolts through the outside, fasten them inside the deck with provided fasteners. 

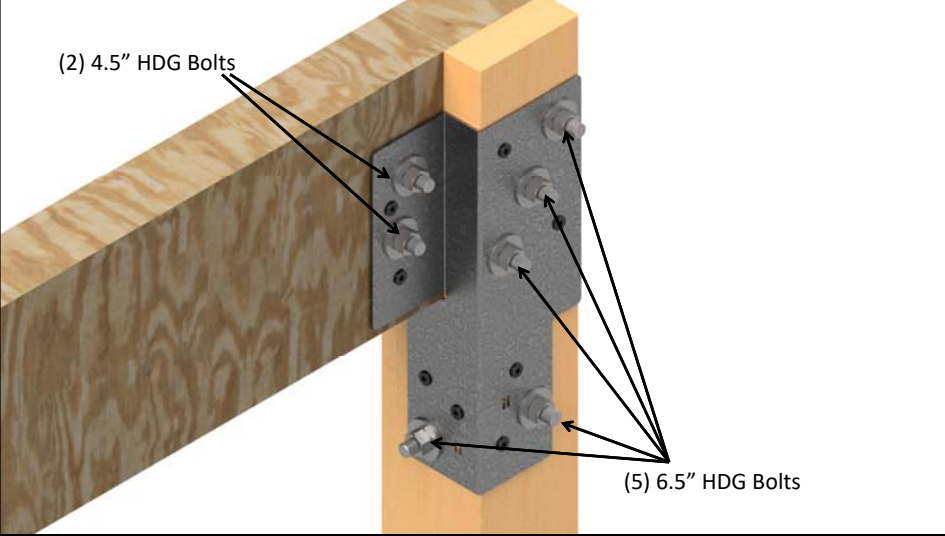

(2) 4.5" HDG Bolts

(5) 6.5" HDG Bolts

Torque per recommended wood council specs. Bolts are 1/2" diameter minimum.
Installation Complete! 7



Beam To Post Brackets Assembly Guide

** Read Guide Completely Before Installation **

Certifications

- HDG, Inc. Engineered Products: **Subject to 1 Year Limited Warranty**
- **USPTO:** No. 10,024,046: Bracket Bracing System
- **Copyright** © 2018 HDG, Inc. ~ All Rights Reserved
- **Terms of Use:** Listed @ www.hdgep.com

**Instructions are not intended to replace deck construction plans.
Shown for product illustration purposes only.**

Contact: info@hdgep.com or (770) 777-7007 Ext 234 for Additional Information
See www.hdgep.com for Instructional Video and Individual Product Specifications